

# Entry 10



## CAPACITY

10 TRAYS GN 1/1 H20 - H40 - H65

10 TRAYS EN 60x40

+90  
▼+3 | 32 kg      +90  
▼-18 | 22 kg

## PROGRAMS

Blast chilling	Shock freezing
Fish sanitizing	Thawing
Pre-cooling	Ice cream hardening
Forced ventilation defrosting.	

## VERSIONI

 S Plug-in air condensing unit

## CONSTRUCTION FEATURES

Controller with 2.8" colour graphic display, capacitive keys and IP65 front panel with continuous surface.

Monocoque construction.

Internal and external construction in AISI 304 stainless steel.

Stainless steel feet adjustable in height.

Door gasket resistant to minimum reaching temperatures.

Cabinet profiles and door profiles resistant to minimum temperatures.

Technical compartment placed under the cabinet.

Condensing unit placed in the technical compartment, removable and easily inspectable from the back.

AISI 304 stainless steel tray holder, suitable to hold GN 1/1 and EN60x40 trays. Easily removable structure for cleaning operations.

Internal cell with rounded corners to facilitate cleaning operations.

CFC-free high density polyurethane insulation.

Evaporator with cataphoresis rust protection.

Left side door hinge.

Heated door perimeter to avoid frost formation.

## STANDARD EQUIPMENT

 n° 1 core probe.

 AISI 304 stainless steel tray holder

 Stainless steel feet adjustable in height.

## FUNCTIONS

Simple and intuitive controller graphics.

Possibility to choose between factory preset cycles or manual cycles.

Automatic holding at the end of the cycle.

Acoustic signals.

Control and save HACCP data in the cloud. (optional with bluetooth or wifi connection kit)

Probe cycles: the core probe temperature controls the cycle ensuring control and precision.

Time cycles: the set duration controls the cycle.

Preset cycles per recipe: for blast chilling and shock freezing cycles, it is possible to choose preset parameters according to the type of product to be treated.

Soft and Hard cycles: possibility of choosing between Soft or Hard blast chilling or shock freezing cycles.

## OPTIONAL EQUIPMENT

 Kit of casters.

 Door with hinge on right side.

 Control and save HACCP data in the cloud. (optional with bluetooth or wifi connection kit)

<b>Technical data</b>	S
Cooling capacity (Evap. -10°C / Cond. 45°C)	2411 W
Condensation	self-contained air
Refrigerant gas	R290
GWP	3
Climate class	4
Power supply (Ph / Volts / Hz)	220-240/1N/50
Max. power consumption cold cycles	1531 W - 6.13 A
Blast chilling (+90 °C, +3 °C)	32 kg
Shock freezing (+90°C, -18°C)	22 kg
Internal dimensions (wxpxh)	615 x 417 x 775 mm
External dimensions (wxpxh)	715 x 695 x 1412 mm
Capacity (liter)	199 L
Packaging dimensions	730 x 755 x 1555 mm
Packing volume	0.9 m <sup>3</sup>
Gross weight	132 kg

<b>EN22042</b>			
<b>+65°C +10°C</b>	<b>kWh/Kg</b>	0,099	<b>+65°C -18°C</b>
	<b>Min.</b>	96	
	<b>Kg</b>	27	
	<b>kWh/Kg</b>	0,286	
	<b>Min.</b>	264	
	<b>Kg</b>	17	

GASTRONOMIA / GASTRONOMY

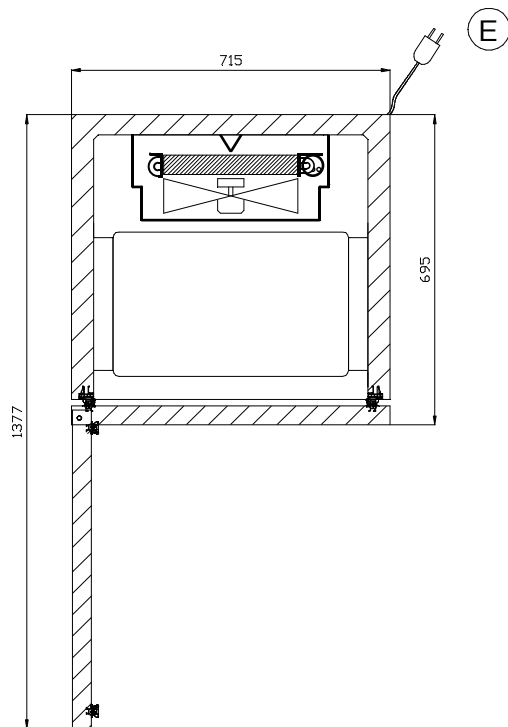
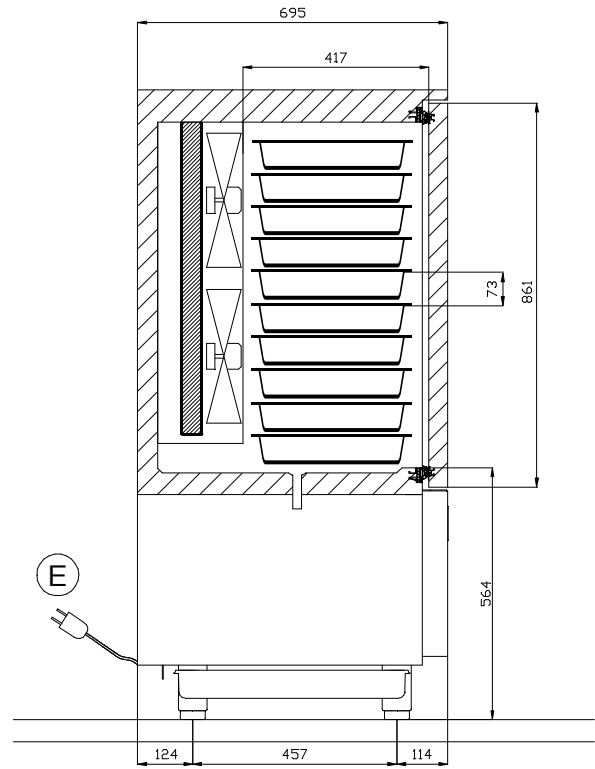
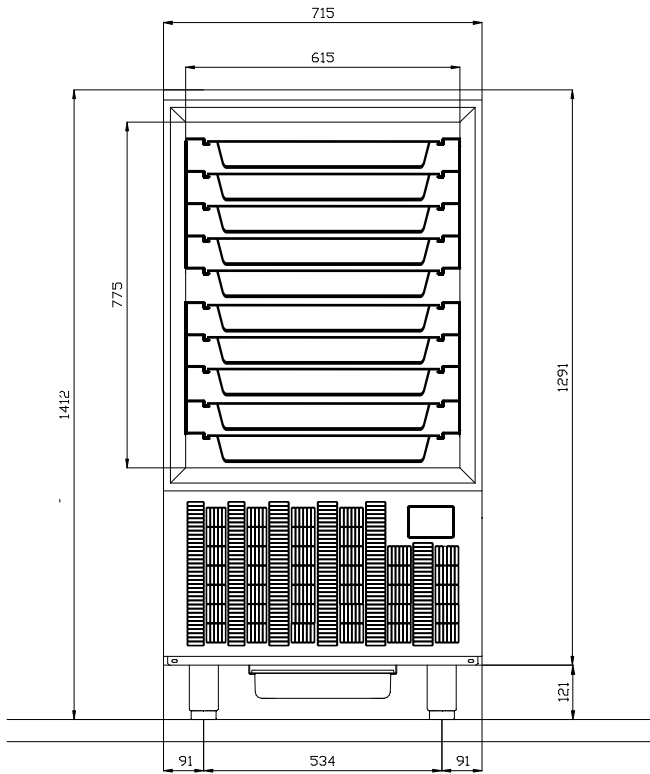

 H MIN 120 mm  
H MAX 165 mm

 CONNESSIONE ELETTRICA  
ELECTRICAL CONNECTION

PASTICCERIA / PASTRY

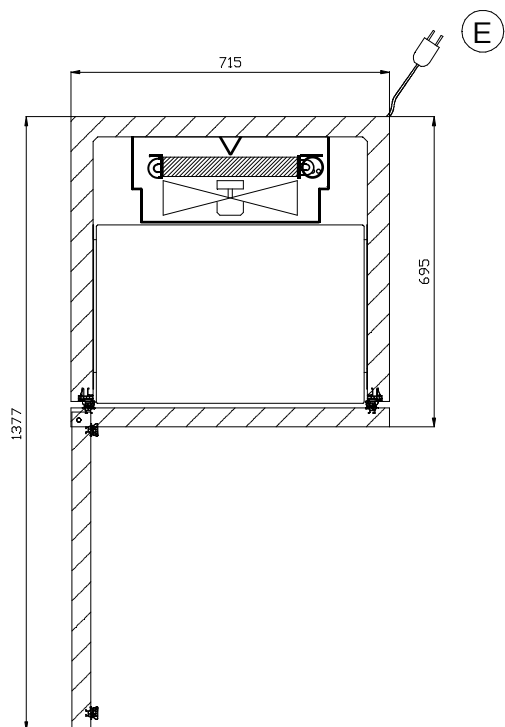
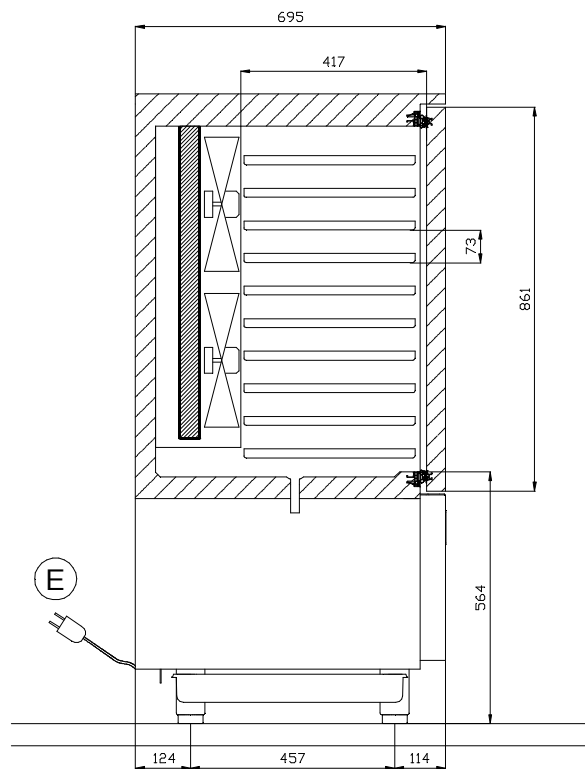
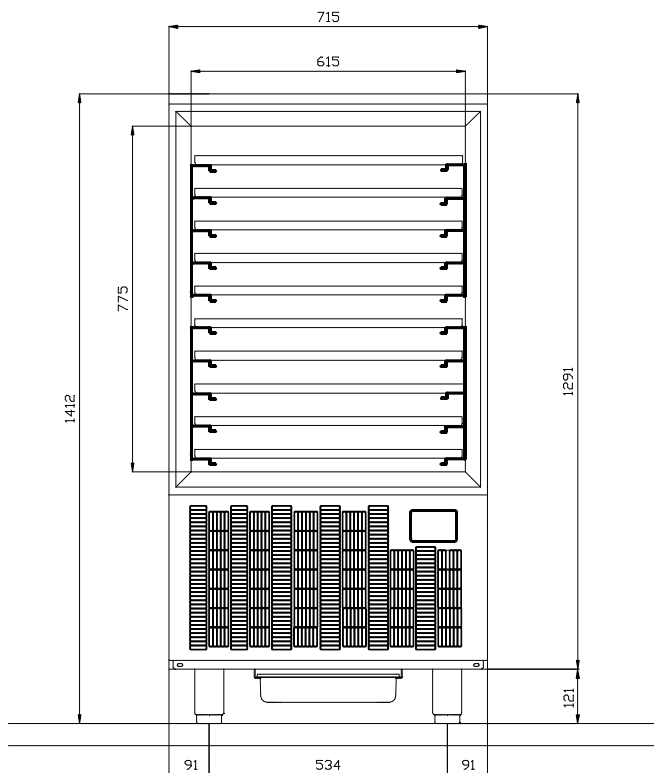

 H MIN 120 mm  
H MAX 165 mm

 CONNESSIONE ELETTRICA  
ELECTRICAL CONNECTION

GELATO / ICE CREAM

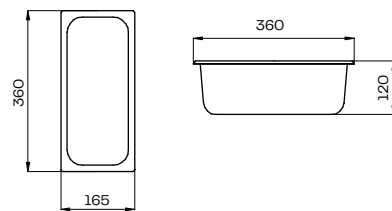
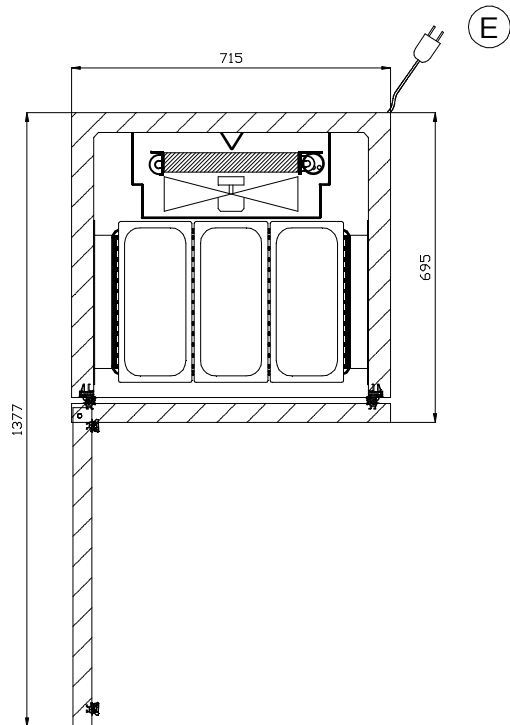
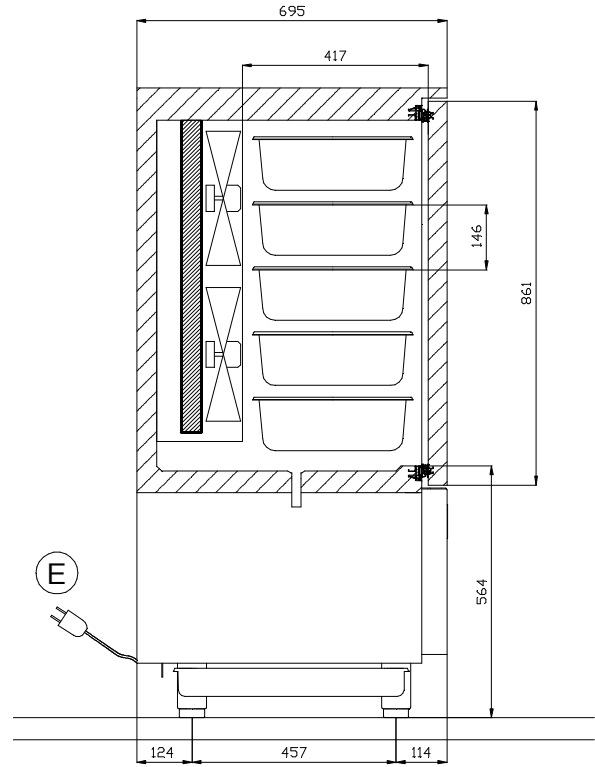
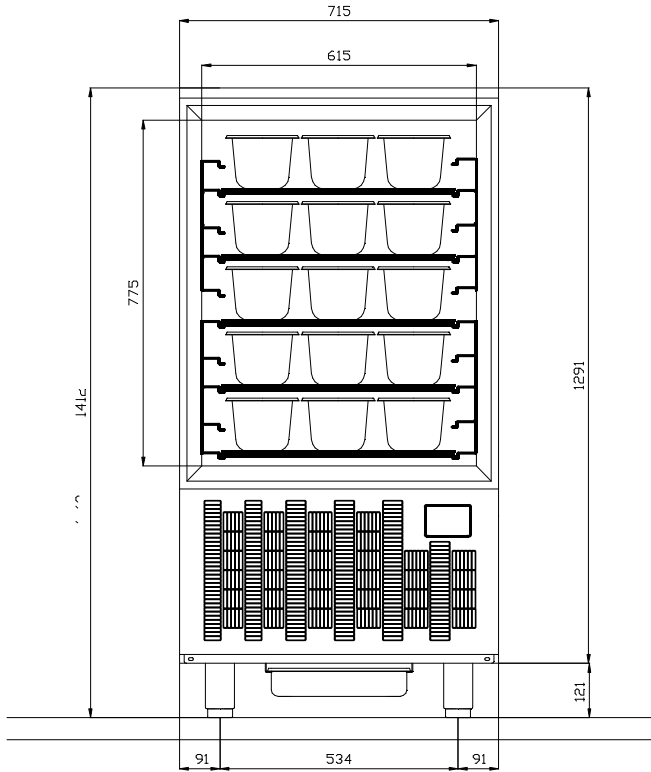

H MIN 120 mm  
H MAX 165 mm

**E** CONNESSIONE ELETTRICA  
ELECTRICAL CONNECTION